

DASHANG
大上电器

DUSUNG
Refrigeration

DASHANG
大上电器

DUSUNG
Refrigeration

DASHANG REFRIGERATION PRODUCT CATALOG 2025

All series of commercial refrigeration
equipments will provide you the refrigeration beyond imagination.



Qingdao Dashang Electric Appliance Co., Ltd

No. 70 Jinsheng 1 Road, Chengyang District, Qingdao, Shandong Province, China

🌐 Web: www.dashangrefrigeration.com

✉ Email: info@dashangrefrigeration.com

Qingdao·China

DASHANG
大上电器

DUSUNG
Refrigeration

TOGETHER TO CREATE A COOLER WORLD





CONTENTS

01

About Company

page
01-04

02

Island Freezer & Combined Freezer

page
05-013

03

Air-curtain Upright Fridge

page
014-026

04

Glass-door Upright Fridge/ Freezer

page
027-036

05

Fresh-food Cabinet

page
037-048

06

Deli Cabinet

page
049-054

07

Recent Cases

page
055

DASHANG
大上电器



Kenkuhl®

中科绿能
ZOCOLN



Pillars

Craftsmanship, Creativity,
Quality, Synergy

Value

Innovation, Cooperation,
Sustainability, Integrity

Vision

Together to create a
cooler world

DASHANG
大上电器

For 23 years, dashang has dedicated to meet the needs of various segments in the global commercial refrigeration field, relying on exceptional craftsmanship, creativity, quality, and synergy.

Our product range includes refrigerated display cabinets, stainless steel cabinets, refrigeration units, and panels, catering to the various needs of retail, food and beverage, and Ho.Re.Ca. markets, providing a one-stop shopping service.

We consistently commits to learning from global markets, providing partners with the latest market insights, extensive product experience, and reliable products, to benefit the partners' brands and their final users.

DASHANG'S PRODUCTION CAPABILITY

Dashang's production capabilities are marked by advanced technology and a commitment to efficiency. Our manufacturing facilities, equipped with state-of-the-art machinery and spanning extensive areas, enable us to produce a wide variety of commercial refrigeration products.



The integration of automated processes and rigorous quality control systems ensures that our products meet the highest standards of reliability and performance. With a focus on innovation and sustainability, Dashang continually adapts its production methods to align with global market demands and environmental considerations. This robust production infrastructure positions us to effectively serve our diverse clientele across the world.





GLOBAL SERVICE NETWORK









Over the past decade, Dashang has provided outstanding refrigeration services and products to customers in more than 60 countries around the world.



AMERICANO

Island Freezer

PRODUCT FEATURES

-  4 layers front glass
-  Vertical evaporator
-  Famous brand compressor
-  Widened transparent window
-  User-friendly handles
-  Larger opening area
-  Energy saving and high efficiency
-  Auto defrosting

PRODUCT PERFORMANCE

Model	Size(mm)	Temperature range(°C)
HW18A/ZTB-U	1870*875*835	-18~-22
HN14A/ZTB-U	1470*875*835	-18~-22
HN18A/ZTB-U	1865*875*835	-18~-22
HN21A/ZTB-U	2115*875*835	-18~-22
HN25A/ZTB-U	2502*875*835	-18~-22



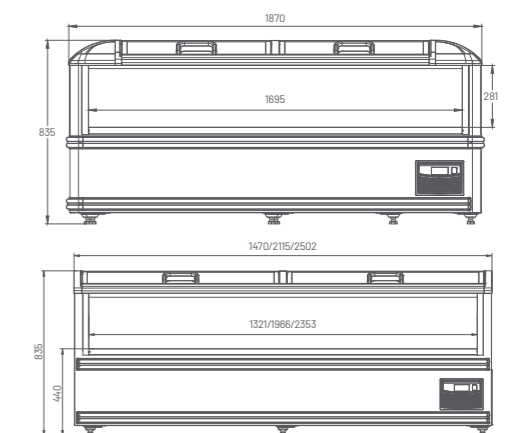





SECTIONAL VIEW



ESPRESSO

Island Freezer

PRODUCT FEATURES

-  Copper tube evaporator
-  Famous brand compressor
-  Energy saving and high efficiency
-  RAL colour choices
-  Intelligent temperature controller
-  Tempered and Low-E coated glass
-  Rich accessories
-  Auto defrosting

PRODUCT PERFORMANCE

Model	Size(mm)	Temperature range(°C)
HW18-L	1870*875*835	-18~-22
HN14A-L	1470*875*835	-18~-22
HN18A-L	1865*875*835	-18~-22
HN21A-L	2115*875*835	-18~-22
HN25A-L	2502*875*835	-18~-22



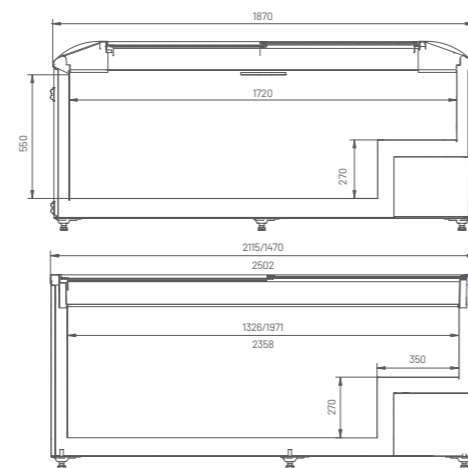



SECTIONAL VIEW



ESPRESSO

Island Freezer

PRODUCT FEATURES

-  Copper tube evaporator
-  Famous brand compressor
-  Energy saving and high efficiency
-  RAL colour choices
-  Intelligent temperature controller
-  Tempered and Low-E coated glass
-  Rich accessories
-  Auto defrosting

PRODUCT PERFORMANCE

Model	Size(mm)	Temperature range(°C)
HW18-U	1870*875*835	-18~-22
HN14A-U	1470*875*835	-18~-22
HN18A-U	1865*875*835	-18~-22
HN21A-U	2115*875*835	-18~-22
HN25A-U	2502*875*835	-18~-22

SECTIONAL VIEW

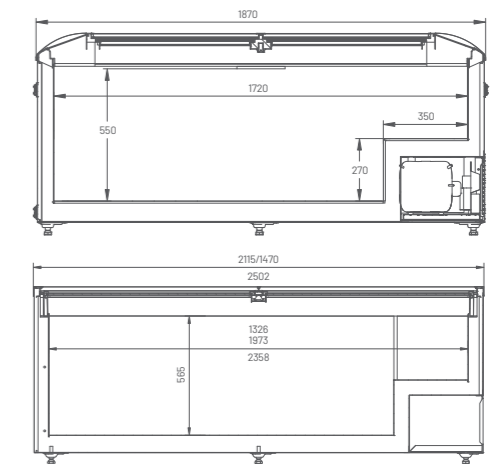

CAPPUCCINO

Island Freezer

PRODUCT FEATURES

- 4 layers front glass
- Vertical evaporator
- Famous brand compressor
- Widened transparent window
- User-friendly handles
- Larger opening area
- Energy saving and high efficiency
- Auto defrosting

PRODUCT PERFORMANCE

Model	Size(mm)	Temperature range(°C)
HW18A/ZTS-U	1870*875*835	-18~-22
HN14A/ZTS-U	1470*875*835	-18~-22
HN18A/ZTS-U	1865*875*835	-18~-22
HN21A/ZTS-U	2115*875*835	-18~-22
HN25A/ZTS-U	2502*875*835	-18~-22

SECTIONAL VIEW

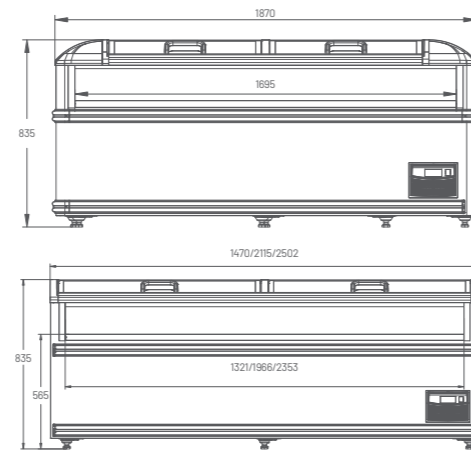

CAPPUCCINO PRO

Island Freezer

PRODUCT FEATURES

- 4 layers front glass
- Vertical evaporator
- Famous brand compressor
- Widened transparent window
- Refrigerated drawer
- Larger opening area
- Energy saving and high efficiency
- Auto defrosting

PRODUCT PERFORMANCE

Model	Size(mm)	Temperature range(°C)
HW18C/ZTS-U	1870*875*835	-18~-22
HN14C/ZTS-U	1470*875*835	-18~-22
HN18C/ZTS-U	1865*875*835	-18~-22
HN21C/ZTS-U	2115*875*835	-18~-22
HN25C/ZTS-U	2502*875*835	-18~-22

SECTIONAL VIEW

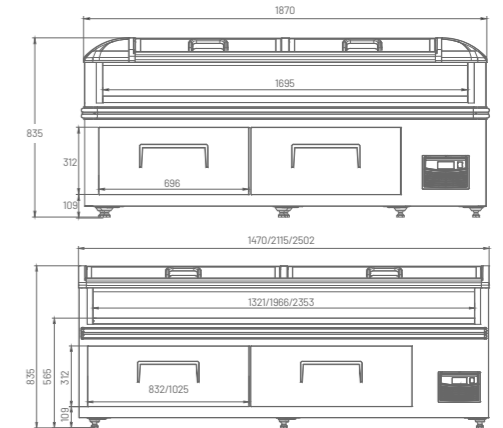

LATTE

Island Freezer

PRODUCT FEATURES

- Vertical evaporator
- Widened transparent window
- Energy saving and high efficiency
- Save space
- 4 layers front glass
- Larger opening area
- Rich accessories
- Auto defrosting

PRODUCT PERFORMANCE

Model	Size(mm)	Temperature range(°C)
HW15E/ZTB-U	1500*875*950	-18~-22
HN21E/ZTB-U	2115*1500*950	-18~-22
HN25E/ZTB-U	2502*1500*950	-18~-22

SECTIONAL VIEW

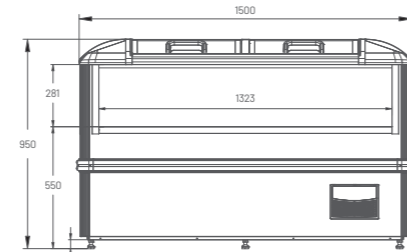

GIANT

Freezer Combination

PRODUCT FEATURES

- Multiple combination choices
- Famous brand compressor
- Energy saving and high efficiency
- Copper tube evaporator
- High-level compression resistance capacity
- Optimized height and display design
- Auto defrosting
- RAL colour choices

PRODUCT PERFORMANCE

Model	Size(mm)	Temperature range(°C)
ZM14B/X-L01&HN14A-L	1470*1090*2385	-18~-22
ZM21B/X-L01&HN21A-L	2115*1090*2385	-18~-22
ZM25B/X-L01&HN25A-L	2502*1090*2385	-18~-22



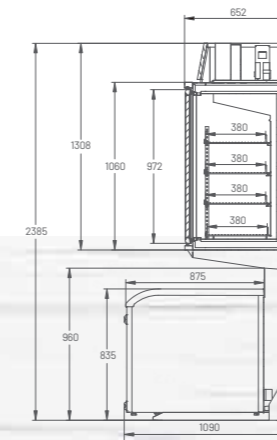





SECTIONAL VIEW



SMART

Small Freezer Combination

PRODUCT FEATURES

-  Multiple combination choices
-  Famous brand compressor
-  Energy saving and high efficiency
-  Copper tube evaporator
-  High-level compression resistance capacity
-  Optimized height and display design
-  Auto defrosting
-  RAL colour choices

PRODUCT PERFORMANCE

Model	Size(mm)	Temperature range(°C)
ZM12X-L01&HN12A/ZTS-U	1200*940*2140	-18~-22
ZM14X-L01&HN14A/ZTS-U	1470*940*2140	-18~-22

SECTIONAL VIEW

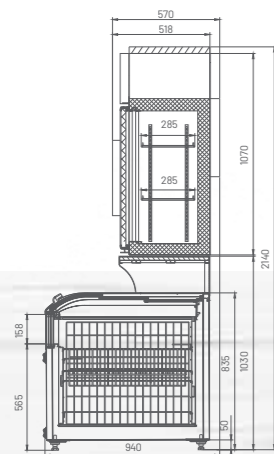

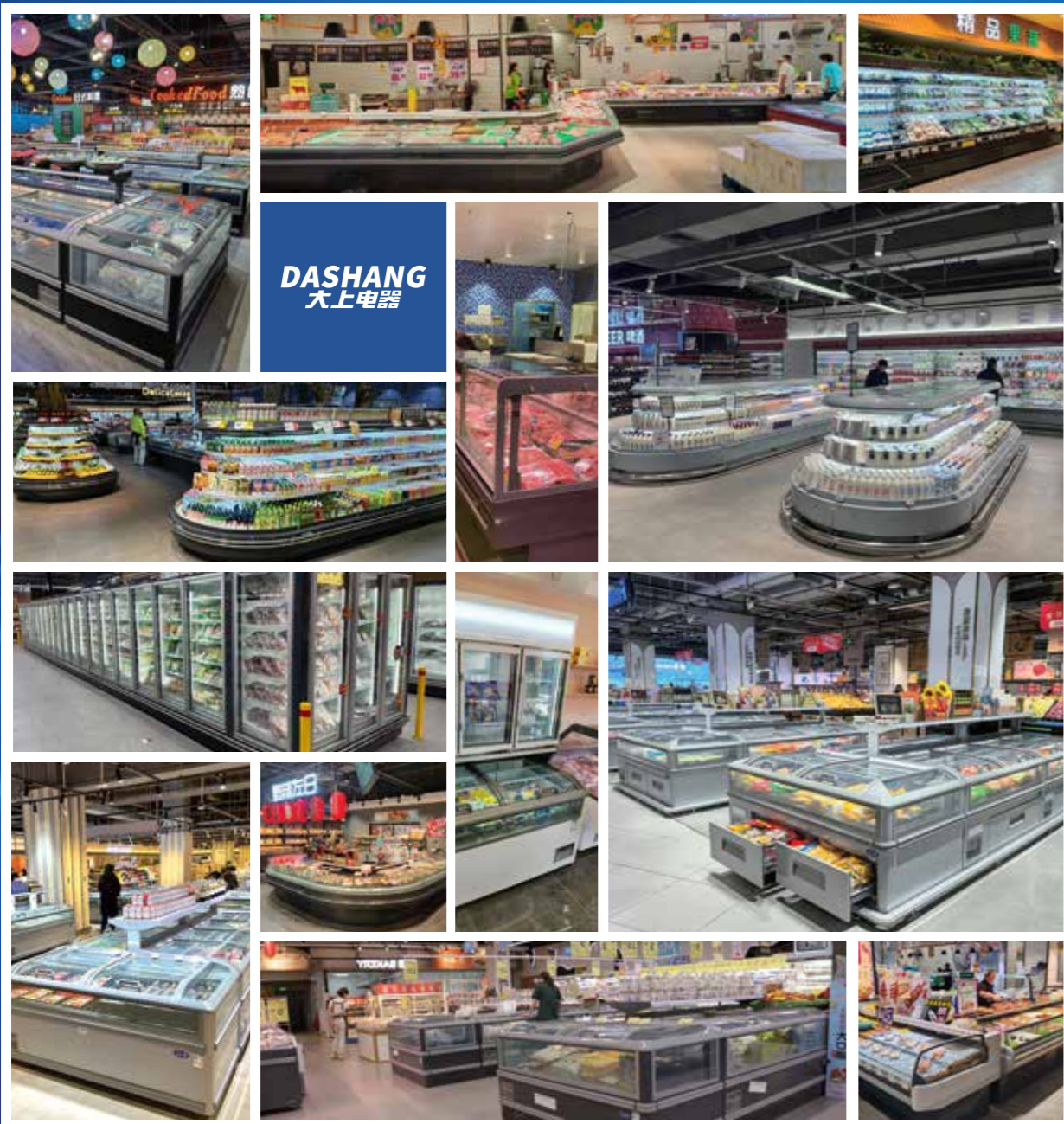

DASHANG
大上电器

DASHANG
大上电器

DUSUNG
Refrigeration